

CHATHAM FOREST

COMMUNITY ARCHITECTURAL CONTROL GUIDELINES

SEPTEMBER 2006

Table of Contents

SECTION I: GENERAL	1.1
Introduction.....	1.2
Governing Article.....	1.3
<i>Architectural Control Committee</i>	1.3
<i>Purpose of the ARCHITECTURAL Control Committee</i>	1.3
<i>Requirement</i>	1.3
<i>Procedures</i>	1.3
<i>Guidelines</i>	1.3
Covenants, Conditions and Restrictions.....	1.5
Disclaimer.....	1.6
SECTION II: PROCEDURE FOR REQUESTING ARCHITECTURAL APPROVAL	2.1
Application Instructions.....	2.2
Application Form.....	2.4
SECTION III: ARCHITECTURAL GUIDELINES	3.1
Structural, Architectural or Exterior Changes to Home.....	3.2
<i>Porches / Screen Porches / Canopies / Solar Sunscreens / Awnings /</i> <i>Trellis / Arbors / Tents</i>	3.2
<i>Patios / Decks / Patio Extensions</i>	3.2
<i>Screen Porches and Deck Enclosures</i>	3.3
Appearance.....	3.3
Location.....	3.3
Materials.....	3.3
<i>Storm Doors</i>	3.4
Fences.....	3.5
<i>Approved Styles</i>	3.5
<i>Appearance</i>	3.5
<i>Location</i>	3.5
<i>Placement on House</i>	3.6
<i>Materials</i>	3.7
<i>Standard Fence Installation Guidelines</i>	3.7
<i>Standard Fence Style Details - SCALLOPED</i>	3.8
<i>Standard Fence Style Details – DOG EARED STRAIGHT TOP</i>	3.9
<i>Standard Fence Style Details – GOTHIC</i>	3.10
<i>Standard Fence Style Details – PRIVACY ARCH TOP</i>	3.11
Parking Pads.....	3.12
Appearance.....	3.12
Location.....	3.12
<i>Drainage / Slope</i>	3.12
Materials.....	3.12

<i>Parking Pad Detail</i>	3.13
Play Equipment.....	3.14
<i>Appearance</i>	3.14
<i>Location</i>	3.14
<i>Materials</i>	3.14
Landscaping.....	3.15
<i>General Information</i>	3.15
<i>Tree Removal</i>	3.15
<i>Gardens (Vegetable or Water)</i>	3.16
<i>Gardens (Flower)</i>	3.16
<i>Gardens (Rain)</i>	3.16
<i>Patios</i>	3.16
<i>Walkways</i>	3.16
<i>Landscape Beds</i>	3.17
<i>Other (Gazebos, Planters, Retaining Walls, Exterior Lighting, etc.)</i>	3.17
<i>Lawn / Grass</i>	3.17
<i>Compost Bns</i>	3.17
Antennas and Satellite Dishes.....	3.18
Storage Sheds.....	3.19
<i>Appearance</i>	3.19
<i>Location</i>	3.19
<i>Materials</i>	3.19
Basketball Goals, Trampolines and Other Sports Equipment.....	3.20
<i>Basketball Goals – General</i>	3.20
<i>Portable Goals</i>	3.20
<i>Permanent Pole – Mounted Basketball Goals</i>	3.20
<i>Permanent Goal Mounted to a House</i>	3.20
<i>Trampolines</i>	3.21
<i>All Other Sports Equipment</i>	3.21
Pet / Animal related Details.....	3.21
<i>Dog Houses</i>	3.21
<i>Pets / Animals</i>	3.21
Flags, Statuary and Other Exterior Details.....	3.22
<i>Flags</i>	3.22
<i>Statuary</i>	3.22
Trash Receptacles.....	3.22
Holiday Decorations.....	3.22
Mailboxes.....	3.23
Yard Lights.....	3.24
Pools.....	3.25
SECTION IV: MAINTENANCE.....	4.1
Maintenance.....	4.2
Deterioration.....	4.2

Architectural Control

Page 1.1

Section I: General

Architectural Control

Page 1.2

Introduction

WELCOME to the Chatham Forest Community. Chatham Forest is an exciting and vibrant place in which to live and the people here wish to make it an even better place to call home through their continuing efforts to protect, maintain and enhance their property values.

Chatham Forest is what is known as a planned subdivision. This means that the original tract of property was site-planned, designed, and approved as a self-contained, deed restricted community which would have its own set of covenants and conditions and order of rule under which all property owners would live and abide and which would provide for maintenance of all Common Properties and improvements thereon (see your Covenants, Conditions and Restrictions Documents). Conditions and restrictions were set so that the aesthetics, congruity, appearance, safety, etc., would be defined and written guidelines would be promulgated (e.g. this handbook) in order to create an environment where all homeowners could live in harmony. Each homeowner would then have some degree of assurance that the actions of all members of the community would be directed so as not to adversely impact their quiet enjoyment or property values (e.g. painting one's home bright orange; abandoning cars in the street or driveway; the keeping/breeding of vicious pets such as pit bulls; unkempt yards, etc.). In effect, Chatham Forest is a "mini city" where there is a mayor (Board President), a city council (Board of Directors), a city manager (Property Manager), advisors (Committee Members), and citizens (Homeowners). The ultimate intent, then, is not to create a totalitarian environment where property rights are trampled, but rather a self-ruled community where its members (homeowners) look after their home and hearth and, ultimately, their investment through active participation in the governance of the community and on committees advising its appointed or elected leaders.

A well-run community makes for a pleasant community in which to live. This document sets forth the guidelines and procedures for making an application for approval for changes to the exterior of your home or yard. Some changes do not need prior Architectural Control Committee approval and they are covered elsewhere in this booklet; all other exterior changes must come before the Architectural Control Committee, including any that are not covered in this booklet. Please read on and familiarize yourself with the information contained herein.

Architectural Control

Page 1.3

Governing Article

ARCHITECTURAL CONTROL COMMITTEE

An Architectural Control Committee consisting of at least three persons who are appointed by the Association's Board of Directors and is responsible to the Board.

PURPOSE OF THE ARCHITECTURAL CONTROL COMMITTEE

The Architectural Control Committee shall regulate the external design, appearance, and location of improvements on the Properties in such a manner to (i) promote those qualities in the environment and that bring value to the Properties and (ii) foster the attractiveness and functional utility of the community as a place to live, including a harmonious relationship among structures, vegetation, and topography.

REQUIREMENT

No building, fence, wall, residence, structure, or projection from a structure (whether of a temporary or permanent nature, and whether or not such structure shall be affixed to the ground) shall be commenced, erected, maintained, improved, or altered, nor shall any grading, excavation, tree removal, planting, change of exterior color or other work which in any way alters the exterior appearance of any Lot or improvement be done without the prior written approval of the Architectural Control Committee regarding (i) the harmony of its exterior design and location in relation to other Properties (ii) the character of the exterior materials and (iii) the quality of the exterior materials and workmanship.

PROCEDURES

In the event the Architectural Control Committee fails to approve or disapprove in writing an application within forty-five (45) days after the plans and specification in writing have been submitted to it in accordance with adopted procedures, approval will be deemed granted. The applicant may appeal an adverse Architectural Control Committee decision to the Association's Board of Directors, who may reverse or modify such decision by a two-thirds vote of those directors present and voting at a meeting at which a quorum is present.

GUIDELINES

The Architectural Control Committee shall, subject to the approval of the Board of Directors of the Association, develop and promulgate policy guidelines for the application of the design review provisions in this Declaration. The policy guidelines shall include (i) review procedures (ii) objectives of review, and (ii)

Architectural Control

Page 1.4

principles and criteria used as standards in determining the achievement of their required objectives. The policy guidelines may also include specific design practices that, though optional, are generally acceptable methods for achieving the required objectives in particular design problems frequently encountered in the Properties. The policy guidelines are intended to assist the Architectural Control Committee and the Owners of Lots in the ongoing process of community design. They may be modified and supplemented from time to time on due notice to the Owners and subject to the approval of the Board.

Architectural Control

Page 1.5

Covenants, Conditions, and Restrictions

(The following is reprinted from the Declaration of Covenants, Conditions, and Restrictions, a copy of which you received at the time you contracted for your purchase).

ARTICLE V

ARCHITECTURAL CONTROL

No building, outbuilding, fence, wall, porch, deck, patio or other structure, landscaping, or tree removal shall be commenced, erected, or maintained upon any of the Lots, nor shall any exterior addition to or change or alteration therein be made until the plans and specifications showing the nature, kind, shape, height, materials, schedule of exterior color, finish, roofing, changes in topography and or elevation, landscaping, tree disturbance or removal and locations of the same shall have been submitted to and approved in writing by the Declarant, or his successor and assigns, as to the harmony of external design and location in relation to surrounding structures, topography, and appearance. Declarant, or his successor and assigns, shall have the sole and absolute right to disapprove any plans or specifications so submitted and Declarant's decision shall be final and not subject to review or appeal. The Declarant, or his successors and assigns, shall have the right to inspect all construction and/or land disturbance to ensure that such work is performed in accordance with the approved plans and specifications and Declarant shall have the right to bring action to enjoin any activity taken in violation of this provision.

As of December 31, 2007, Declarant's responsibility pursuant to this Article shall pass to and become the responsibility of the Board of Directors of the Association or any Architectural Review Committee established by the Board, said committee to consist of no less than three (3) representatives appointed by the Board. The Declarant, in his sole discretion, shall have the right to convey his responsibility by written letter to the Association prior to December 31, 2007.

Architectural Control

Page 1.6

Covenants Conditions, and Restrictions (Cont.)

(See Also **Article VI "EASEMENTS"** of the Covenants, Conditions, and restrictions)

(See also **Article VII "USE RESTRICTIONS"** of the Covenants, Conditions, and Restrictions).

Disclaimer

The Association, Declarant, Architectural Control Committee, or any officer, employee, agent, director or member thereof shall not be liable for damages to any person(s) submitting plans and specifications for approval by reason of mistake in judgment, negligence or nonfeasance arising out of or in connection with the approval, disapproval or failure to approval any plans and specifications. Every person who submits plans and specifications for approval agrees, by submission of such plans and specifications, that he will not bring any action or suit against the Association, Declarant, or Architectural Control Committee to recover any such damages.

Architectural Control

Page 2.1

Section II: Procedure for Requesting Architectural Approval

Architectural Control

Page 2.2

Application Instructions

ARCHITECTURAL CONTROL APPLICATION INSTRUCTIONS

STEP 1. Prior to any alteration, addition or improvement for which approval of the Architectural Committee ("Committee") is required pursuant to the Declaration, the Lot Owner (and not a contractor or third party) must complete a **Request for Architectural Approval** form (the "Application"). This form may be obtained by request from the Association's management company (or copied directly from this handbook) and used for making an application to the Committee. The completed form is to be sent to the management company at:

Magnolia Management Group, Inc.
PO Box 1847
Pittsboro, NC 27312
Phone: 919-545-2240 Fax 919-542-3358
Attn: CHATHAM FOREST Architectural Control

STEP 2. The Management Company, upon request, will promptly forward to the Lot Owner the Application, along with a copy of any Rules and Regulations and any architectural standard bulletins promulgated by the Committee, from time to time.

STEP 3. The Application must be completed, together with any supporting documents that are, either required by the Declaration or by the architectural standards of the Committee, and returned to the Management Company at the address shown above. **All documents must be on standard letter or legal size paper.**

STEP 4. The Management Company will mark and record the date the Application is received by it. The Management Company will then copy and distribute the completed Application to the Committee. The Management Company will contact the homeowner submitting application by phone or letter within 10 business days to provide a confirmation receipt number. The application is not considered "received" until confirmation number is given.

STEP 5. Completed Applications that are received by the Management Company by the tenth (10th) day of any month will be considered and acted upon by the Committee in that month. Any Application that is received by the Management Company after the tenth (10th) day of the month will be considered and acted upon by

Architectural Control

Page 2.3

Application Instructions (Cont.)

the Committee in the following month. An Application may be received only on a regular business day. The purpose of this rule is to allow the Committee to duly consider and act upon all Applications received within a given time period on a regular and periodic basis. Note: The Management Company will confirm receipt of application within ten business days by providing a receipt confirmation number. If number is not provided, it is homeowner's responsibility to follow up with Management Company. Receipt of application is confirmed only with assignment of number.

STEP 6. The Committee may (i) approve an Application; (ii) conditionally approve an Application, if such conditions for approval are stated; (iii) deny an application, if the reasons for denial are stated; or (iv) return an Application and request additional information from the Lot owner regarding the project for which approval is sought. The Committee's decision on an Application, and the date of that decision shall be stated in writing either on the Application or in a separate document that refers to the Application.

STEP 7. Upon its receipt of the Committee's decision upon an application, the Management Company will mark the decision with the date that the decision is forwarded to the Lot Owner and will then forward a copy of the decision to the Lot Owner.

STEP 8. A Lot owner who is not satisfied with the Committee's decision on an application may (i) submit another, different application in which case the application process begins again, or (ii) appeal the Committee's decision as provided below.

STEP 9. In order to appeal the Committee's action on the application, the Lot Owner must submit to the Management Company, within thirty (30) days of the date that the decision is forwarded to the Lot Owner, a written appeal which encloses a copy of the application and the Committee's decision thereon and which sets forth the basis for the Lot Owner's appeal. The Management Company will record the date the appeal is received by it. Appeals that are received by the Management Company by the tenth of the month will be considered by the board of Directors of the Association at its next regular meeting. Appeals that are received by the Management Company after the tenth of the month will be considered by the Board of Directors of the Association at its second regular meeting following the date of the receipt of the appeal.

STEP 10. In the event of a conflict between these Rules and Regulations and the Declaration, the Declaration shall control and take precedence.

Application Form

CHATHAM FOREST
Architectural Control Application Form

Request for Architectural Approval

(Please fill in all items and supply all supporting data as requested. Incomplete forms may cause delays in review of your application. ***Applications involving landscape plantings must include the mature height and girth of each individual planting that will exceed 36" in height.***)

Date: _____ Application Receipt Confirmation #: _____

Property Owner's Name: _____

Property Address: _____

Lot #: _____

Telephone #: (W) _____ (H) _____

E-mail: _____

Magnolia Management Group, Inc.

PO Box 1847

Pittsboro, NC 27312

Phone: 919-545-2240 Fax 919-542-3358

Attn: CHATHAM FOREST Architectural Control

NOTE: Receipt of Application will be confirmed by Magnolia Management within 10 business days of submittal with a confirmation number via phone/letter. If a confirmation number is not received, homeowner assumes that application was misdirected and shall make appropriate follow up. Without a confirmation number, ACC applications are invalid and will not be considered as approved due to non-response of ACC.

Architectural Control

Page 2.5

Description of Improvement:

Construction Materials to be used:

Colors (attach samples if necessary):

Estimated Start Date: _____ Estimated Completion Date: _____

This architectural request form must be accompanied by two (2) different drawings:

- 1). **Plot Plan** - Showing the improvement (*i.e.* deck, fence, landscaping, etc.) and its relationship/distance to property lines, easements, open space, drainage ditches, neighboring homes, etc. (You may have received a surveyor's plot plan of your home at the time of closing).
- 2). **Elevation** - A "head on" view of the requested change, as would be seen in a photograph. This elevation drawing should show height, width, distance above finished grade, and details of the proposed request. Be specific in order to expedite the architectural review process. Photographs or brochure pictures should be submitted along with this request when available/possible.

In applying for the above architectural change, I/we agree to follow to the best of my/our ability (ies) the changes as described and to meet any and all codes, permits or other requirements deemed necessary by local, county, state or other applicable authorities having jurisdiction. I/we also fully understand that the Committee will objectively review a request for architectural change and such application in and of itself does not guarantee its approval, even if other such requests have been previously approved in Chatham Forest.

Owner's Signature: _____ Date: _____

Owner's Signature: _____ Date: _____

Architectural Control

Page 2.6

Community: Chatham Forest
Homeowner: _____
Lot #: _____
Receipt Conf. #: _____

(For Committee Use Only)

The Architectural Control Committee of Chatham Forest Homeowners Association hereby **approves** your architectural request with the following restrictions:

Signature _____ Date: _____

The Architectural Control Committee of Chatham Forest Homeowners Association hereby **disapproves** your request for the following reasons:

Signature _____ Date: _____

Should your request be denied, you may appeal the decision in person at the Chatham Forest Homeowners Association's Board of Directors meeting on _____ to be held at _____ at _____ P.M.

Section III: Architectural Guidelines

Structural, Architectural or Exterior Changes to Home

Changes to the appearance of the exterior of a home require ACC approval. This includes, but is not limited to, the following:

Porches/Screen Porches/Canopies/Solar Sunscreens/Awnings/Trellis/Arbor/Tent

No screen porch, canopy, sunscreen, awning, trellis, arbor or tent may be attached to the front of a house. Application must be submitted to the ACC for addition of porch, screen porch, canopy, sunscreen, awning, trellis, arbor or tent or likenesses thereof for permanent or semi-permanent installation in the backyard. Homeowners are responsible for all necessary building permits. A temporary party canopy for a short, specific event is permitted in backyard without approval.

Patios, Decks, and Patio Extension

Addition of any patio, deck or patio extension must have approval of the ACC. Homeowner is responsible for all necessary building permits. Careful consideration must be given to maintain drainage patterns.

When contemplating adding a wood deck or concrete / brick / paver patio to the rear of your home, it is important that you consider several factors:

1. Water drainage pattern under or around the deck/patio: Improper final drainage can damage the house foundation as well as create an area for insects (e.g. mosquitoes) to breed.
2. Distances of deck/patio to property lines and easements: Ordinances may require that such structures not encroach into easements or to within certain distances from property lines.
3. Privacy screening (whether vegetative or other): You may want to incorporate some type of privacy screening around certain parts of your deck or patio (for your own privacy as well as for the privacy of your neighbors), and so it would be prudent to plan the screening and deck/patio at the same time. Screening, however, is not a requirement when putting in decks or patios.
4. Impervious Conditions (the amount of allowable ground cover by impervious materials)

All requests for decks/patios and the extension of existing decks/patios will be reviewed by the Committee in context to the requester's house and lot as well as surrounding lots and easements. Therefore, details of the size and type of deck/patio are important when making your request to the Committee.

Screen Porches and Deck Enclosures

Appearance

All screen porches and methods of enclosing decks will be approved on a case-by-case basis.

The screen porch or deck enclosure should be of the same color scheme as the house or deck, preferably made from the same siding and roofing materials as the house.

Screen porches and methods of enclosing decks must be permanent in nature. No temporary structures will be allowed. A permanent structure includes walls and a roof attached to the main structure of the house. Wall and roof design will be allowed to vary per individual taste.

Location

Screen porches and methods of enclosing decks must be located on the rear of the house. The homeowner must design the screen porch or deck enclosure within the setbacks of his property and is responsible for obtaining all necessary building permits.**

Materials

The materials for building a screen porch or deck enclosure must be of equal or better quality than the materials used to construct the home or deck.

****NOTE:**

The concrete slab that is poured for your rear patio during construction of your home most likely is not a structural slab (*i.e.* it is not designed to carry the load from a wall and roof assembly). Enclosing a concrete patio, then, will probably require that you take out the existing concrete slab and re-pour a footer slab in its place. Homeowner should verify the type of slab before proceeding.

Storm Doors

The ACC will allow installation of storm doors without the submission of an Architectural Application if the storm door meets the following criteria. Doors must be clear glass from top to bottom, either a single full glass panel, or split glass panels that can be opened to permit ventilation at the top and/or bottom. The split bar must not be greater than 2 inches wide. No cross buck, half glass or screen only styles will be permitted.

Doors must have a metal trim frame that is white, or a color that matches the homes shutters and front entry door color. The glass panel/panels may contain clear, silver or gold etching.

For any other style of storm door an Architectural Control Application Form must be submitted for ACC review and consideration.

Fences

Appearance

Wherever possible, alternatives to hard fencing are recommended (i.e., landscaping and plants). It is also recommended that fencing be "softened" through the use of plant material on the exterior side. The homeowner should be conscious of the fence placement and of adjacent homes when making application in order to avoid visual discord in the community as well as sight obstruction to traffic.

Fence styles and heights for Chatham Forest are limited to the following: Scalloped – 4, 5 or 6 ft in height, Dog Eared Straight Top – 3, 4 or 5 ft in height, Gothic Straight Top – 4 or 5 ft in height, Privacy Arch Top – 5 or 6 ft in height.

No other fence types are allowed in the Chatham Forest community.

The height of the fence should remain uniform for the entire run of the fencing.

Illustrations on the following pages are to be used as details for the chosen fence style.

A minimum of one three-foot wide access gate is required into a fenced-in area.

Fences must be constructed of #2 or better quality "treated" "yellow Pine" lumber.

Fences are to be of quality "treated" wood only and shall remain natural in color or may be stained to one of the two approved stain colors. Painting of fences is **not permitted**. Clear protectants or the approved stains are allowed and should be applied at the homeowner's discretion to protect the fence materials, the appearance thereof and their investment. ***Please note: Clear protectants means products that are CLEAR (without any color added) – similar to Olympic semi-transparent #716 Cedar Natural Tone or Ginger and the standard Thompson's Waterseal.***

Location

Fences shall follow the natural grade of the land and no "stepping" of the fence is allowed. Wherever possible, existing trees should not be removed in order to place the fence. The fence shall be placed one inch (1") inside the owner's property line unless the fence is on the side of a house that faces the street. In a case where a fence runs along a side street, the fence must be four (4) feet inside the property line and care must be taken in order to not block a vehicle's line of vision (ordinances may control the placement of the fence in some

instances). The finished side of the fence (the side with the fence slats) shall face outward from the requester's yard.

Adjacent homeowners wishing to share common fencing must still receive Architectural Control Committee approval for fence placement. **In any case, it is the homeowner's responsibility to check for any easements that may affect placement of fencing.**

Placement On House

The fence must be placed no further forward than 10 feet from the rear corners of the house, except when there is a rear access door into the garage or it is desired to enclose the crawl space access door. There are practical reasons for permitting the access door to be inside the fenced area (*e.g.* to allow pet and children access between the rear yard and the garage). The following fence installation guidelines must be followed:

1. The garage access door (if not part of the original construction) must be installed at the furthest point back on the outside garage wall.
2. The fence can only come forward and attach to the house at sixteen inches (16") past the edge of the exterior door trim.
3. Following # 2 above, the forward fence attachment must not enclose an electric or gas meter (unless extenuating circumstances exist) or be less than ten feet (10') from the front corner of the house.
4. The ACC will require any fence that encloses an access door to have a vegetative screening planted in front of it to soften its forward approach (these plants will be evergreen in nature so as to give a year-around-screening effect).
5. The garage access door must be installed prior to the installation of the fence.
6. No forward-placed fences will be allowed except to accommodate the noted access doors.
7. The fence attachment on the other side of the house shall remain at a maximum of ten feet (10') from the rear corner.
8. The above items notwithstanding, some houses may not be able to enclose an access door because the final placement of the fence may not meet one or more of the above guidelines.
9. Fence placement for corner lots will be reviewed on a case by case basis, however, at no time will the fence be placed forward of the noted 10 ft from the rear corners of the home for at least one side.

The Architectural Control Committee will determine the final placement based on aesthetics and street appearance.

Materials

Only #2, or better quality, treated yellow pine material will be allowed. Fence posts must be anchored in the ground with concrete. At no time will fence posts be more than 8 ft apart. Fences must be assembled on-site. No pre-fabricated panels are permitted.

(See following pages for standard fence details and installation guidelines)

Standard Fence Installation Guidelines

1. Installation contractor (or Homeowner) to locate iron pins marking property corners before installing fence. If irons cannot be located by visual search or with a metal detector, then the homeowner should make arrangements with the surveyor of their plot to relocate missing irons. Contractor must pull string lines after locating irons so that the fence can be installed properly, and as approved, on the property.
2. Contractor (or Homeowner) should verify location of underground utilities before beginning installation.
3. Face of fence (picket side) to face outward from property.
4. Face of fence to be placed at one inch (1") inside property lines (no more, no less), unless approved otherwise by the Architectural Control Committee.
5. Fence to attach at rear sides of house at not more than ten feet (10') forward from the rear corners. Exception: See Section 3.6. ACC approval is required.
6. Do not block drainage patterns across yards with the fence bottom. Care should be taken to maintain existing drainage patterns under the fence, where applicable.
7. **NO PREFABRICATED, STORE-BOUGHT FENCING PANELS ARE TO BE USED.** FENCE TO BE CONSTRUCTED AS SHOWN ON PAGES 3.8 – 3.11 OF THE ARCHITECTURAL APPROVAL MANUAL, OR OF A HIGHER CONSTRUCTION QUALITY (e.g. the addition of an extra horizontal rail).

Standard Fence Styles / Details

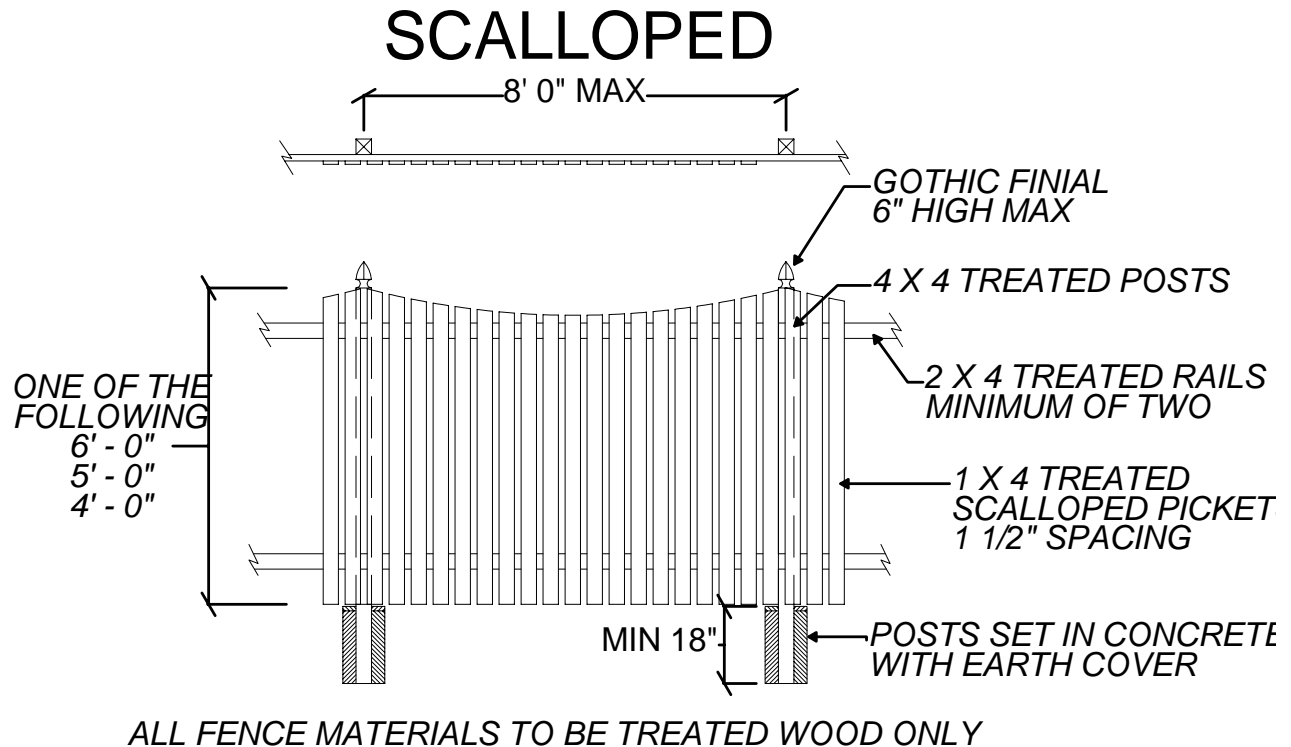

All Fences to be constructed of quality "treated" lumber.

All posts to be set in concrete with earth cover.

No posts will be set further than eight (8) feet apart.

All fence sections to have at least two (2) horizontal rail braces or more when required by height or design.

Allowable fence heights per detail.

Pickets, picket spacing and finial options per detail.

NO PAINTING OF ANY FENCE IS ALLOWED.

PROTECTIVE COATING IS LIMITED TO CLEAR PROTECTANTS OR ONE OF THE TWO APPROVED STAIN CHOICES.

Ample plantings are mandatory to any fences facing a street

Standard Fence Styles / Details Cont.

DOG EARED STRAIGHT TOP

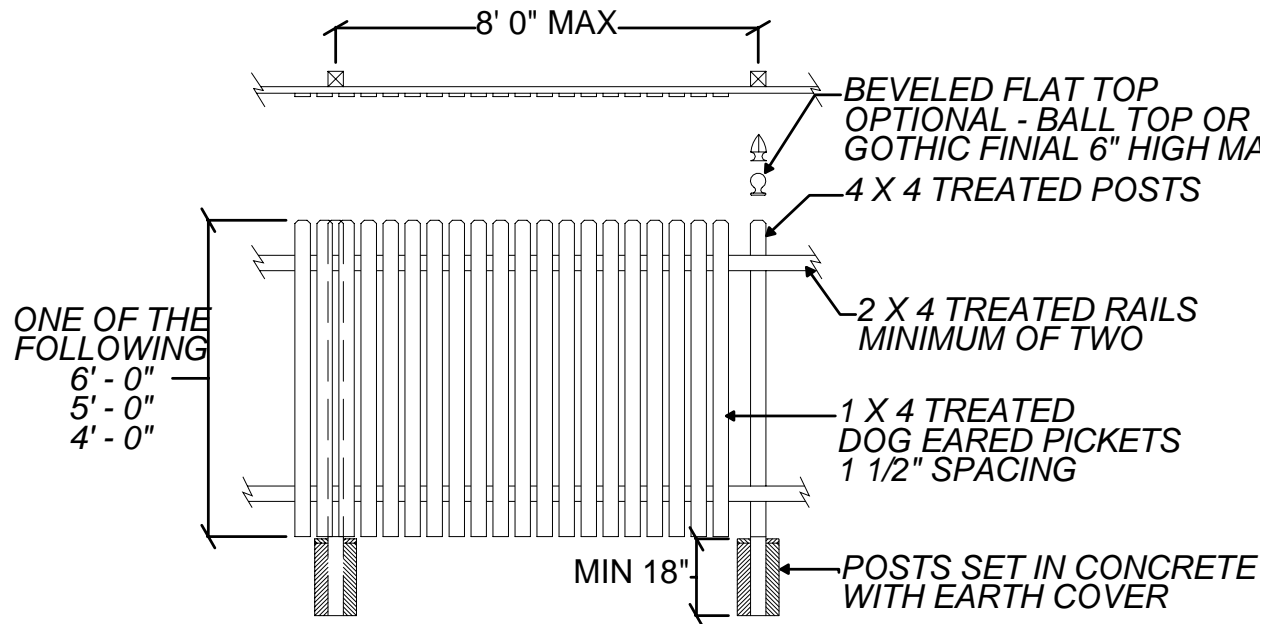

ALL FENCE MATERIALS TO BE TREATED WOOD ONLY

All Fences to be constructed of quality "treated" lumber.

All posts to be set in concrete with earth cover.

No posts will be set further than eight (8) feet apart.

All fence sections to have at least two (2) horizontal rail braces or more when required by height or design.

Allowable fence heights per detail.

Pickets, picket spacing and finial options per detail

NO PAINTING OF ANY FENCE IS ALLOWED.

PROTECTIVE COATING IS LIMITED TO CLEAR PROTECTANTS OR ONE OF THE TWO APPROVED STAIN CHOICES.

Ample plantings are mandatory to any fences facing a street

Standard Fence Styles / Details Cont.

GOTHIC

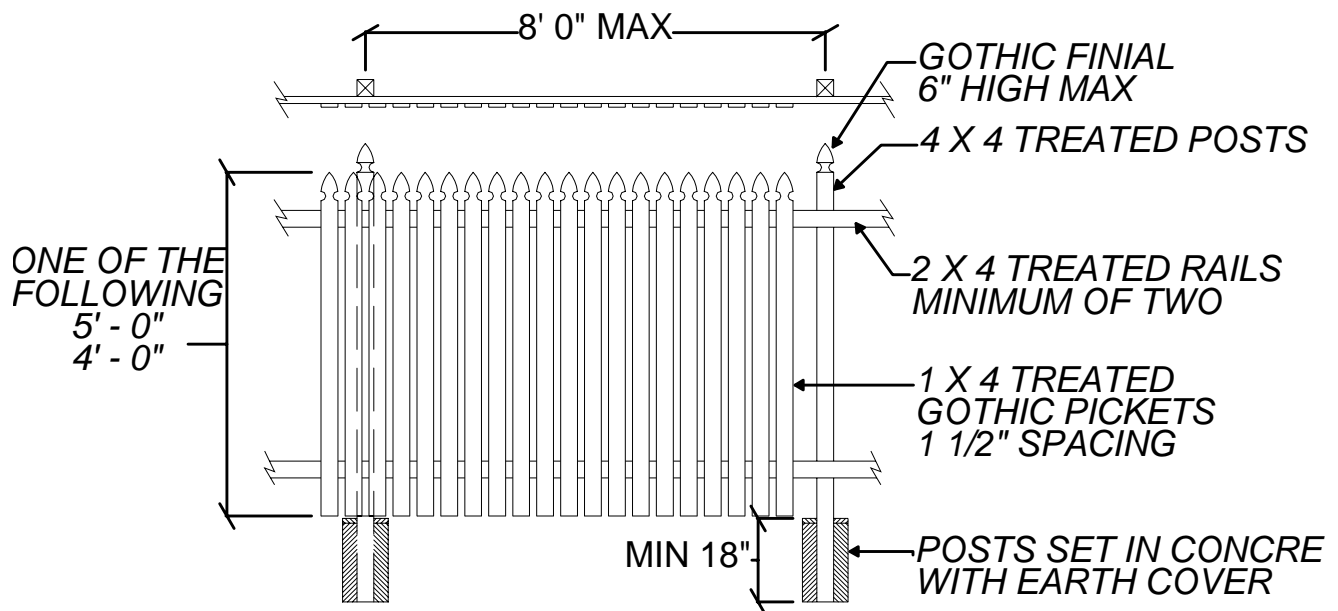

ALL FENCE MATERIALS TO BE TREATED WOOD ONLY

All Fences to be constructed of quality "treated" lumber.

All posts to be set in concrete with earth cover.

No posts will be set further than eight (8) feet apart.

All fence sections to have at least two (2) horizontal rail braces or more when required by height or design.

Allowable fence heights per detail.

Pickets, picket spacing and finial options per detail.

NO PAINTING OF ANY FENCE IS ALLOWED.

PROTECTIVE COATING IS LIMITED TO CLEAR PROTECTANTS OR ONE OF THE TWO APPROVED STAIN CHOICES.

Ample plantings are mandatory to any fences facing a street

Standard Fence Style / Detail Cont.

PRIVACY ARCH TOP (SHADOW BOXED)

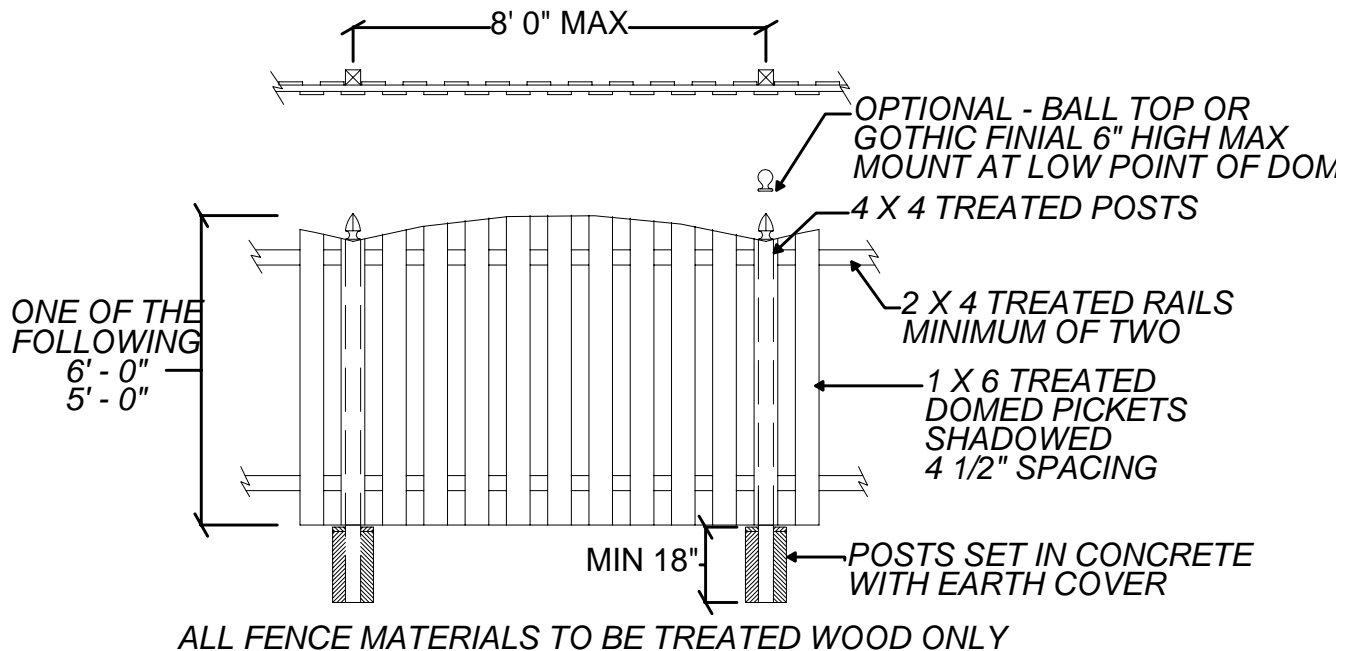

All Fences to be constructed of quality "treated" lumber.

All posts to be set in concrete with earth cover.

No posts will be set further than eight (8) feet apart.

All fence sections to have at least two (2) horizontal rail braces or more when required by height or design.

Allowable fence heights per detail.

Pickets, picket spacing and finial options per detail.

NO PAINTING OF ANY FENCE IS ALLOWED.

PROTECTIVE COATING IS LIMITED TO CLEAR PROTECTANTS OR ONE OF THE TWO APPROVED STAIN CHOICES.

Ample plantings are mandatory to any fences facing a street

Parking Pads

Appearance

Layout (design) should compliment the original driveway and walkway; surface shall be of the same color and finish type as the existing concrete driveway/sidewalk. Approved landscaping may be required to screen the parking area from being visually obtrusive from adjacent lots (as determined by the Architectural Control Committee).

***NOTE: NOT ALL LOTS CAN ACCOMMODATE A PARKING PAD.**

***NOTE: IT IS THE RESPONSIBILITY OF THE HOMEOWNER TO VERIFY THAT THE IMPROVEMENT IN CONJUNCTION WITH EXISTING CONDITIONS DOES NOT EXCEED THE ALLOWABLE 27% IMPERVIOUS CONDITIONS**

Location

Parking pads (driveway extensions) may be constructed adjacent to and contiguous with the original concrete driveway on the side opposite the front walkway. The parking pad shall terminate in line with the front of the house (this will be depending on the style of the home and the grade characteristics of the lot and be reviewed on a case by case basis)

Dimensional Limitations: Maximum width of nine feet. (Each lot will be reviewed.)

Setback Requirements: Minimum setback from side lot line is 18 inches.

Drainage/Slope

Slope of the parking pad and that of the adjacent yard shall preserve the original runoff flow pattern and shall not cause additional water to be directed to a neighboring property or toward the house foundation.

Materials

Concrete shall be the only allowable material. The preparation of the soil base shall be consistent with sound construction practices so as to minimize the risks of settling, excessive cracking, and improper drainage.

(See detailed drawing on the next page)

Play Equipment

Appearance

Playground equipment of a permanent or semi-permanent type requires ACC approval in most instances.

Temporary play equipment such as plastic forts or houses does not require approval, but are only acceptable as one per yard. It is suggested that the plastic-type equipment be removed from view during prolonged periods of non-use.

Swing sets may be installed without ACC approval if size does not exceed 7' high x 13' wide x 9' deep.

Play equipment should blend with the natural surroundings.

Landscaping or fencing should be planned to screen play equipment from being offensive to neighbors and to maintain a safe environment for the children. The size of play equipment shall be proportional and consistent with the surroundings.

Location

Dependent upon the configuration of each lot, play equipment should be placed in the rear yard. Equipment will not be placed within 12' of any property line.

Materials

Equipment constructed from treated natural wood is encouraged; however, the Committee will review other structures. Therefore, detailed drawings, specifications, and coloring shall be required with the Application in order for the Committee to review such a request.

Landscaping

General Information:

CHATHAM FOREST Homeowners Association encourages its homeowners to accent their homes with landscaping elements. Landscaping around the home can add a personal touch and increase the value of one's home. It is encouraged that homeowners seek professional assistance when planning extensive landscape plantings or structures. Several commonly requested landscape elements that need prior approval before building/installing on the property include, but are not limited to, the following list:

- Tree Removal

- Patios

- Walkways

 - Gardens (water, vegetable, rain)

 - Flower beds/gardens (for flowers/plantings growing greater than 24" in height)]

 - Gazebos

 - Planters

 - Retaining walls

 - Exterior lighting

In general, when planning landscaping for any element (including those listed above), one should limit the change in grading of the property to insure proper drainage away from the foundation as well as away from the neighboring properties. Additionally, the planting of shrubs and trees should be made in such a manner that they will not impede the vision of motorists on the street. When submitting an application for landscaping information about the mature height and girth of plantings should be included.

Below are a few of the major categories under landscaping and some standard rules of thumb, which must be considered:

Tree Removal

Chatham Forest would like everyone to preserve and protect the trees on the properties in the subdivision. However, there may be circumstances when tree removal is necessary. It is recommended that living trees with greater than a six-inch diameter not be removed unless they adversely affect the owner's home/property. Trees that are dead and/or present a hazard will receive a priority review.

Gardens (vegetable or water)

These types of gardens shall be located in the rear yard and out of view from the street. (The ACC accepts the fact that this may not be possible in the case of corner lots) Vegetable gardens should be kept clean and clear of high growing weeds when in the off-season. Water gardens should be planned in such a manner as to limit the potential for accidents (e.g., electrocution or drowning).

Gardens (flower)

Flower gardens are highly encouraged and do not require approval in many instances. However, if the plantings exceed 36" in height at full growth or with regular pruning, (24" on either side of the driveway entrance or within ten feet of the intersection on corner lots), then the types of material and placement of such must have Architectural Control Committee approval prior to installation. Planting around street or stop signs cannot be more than 12" high and shall not contain plants of a vine-type variety. Mailbox plant areas cannot be more than 18" high and cannot contain vine-type varieties.

Gardens (rain)

A Rain Garden is an area specially designed to manage rain runoff, and contains plant types adapted to water. No ACC approval is required if the plantings fall within the stated guidelines. However, if the plantings exceed 24" in height at full growth or with regular pruning, then the types of material and placement of such must have Architectural Control Committee approval prior to installation.

Compost bins

Composting is permitted only in commercially manufactured bins designed specifically for suburban composting. Any such bin must be covered at all times

The maintenance of accumulated waste plant materials is prohibited except as part of an established compost system which shall be maintained in such manner as not to be visible from neighboring property. Compost bins may only be placed within the imaginary lines running from the sides of the home to the rear property line and no less than three feet from an ACC approved fence in all directions

Should an adjacent property owner complain regarding odors, rodents or other animals that are attracted to the bin, the association will notify the owner in writing and they must immediately remedy the situation. In the event the owner does not abate the problem within a reasonable amount of time, the association shall have the right, without further notice, to enter the property, eradicate the problem and charge any expense incurred as an assessment against the lot. The assessment can be foreclosed in the usual manner if it remains unpaid for 30 days.

Patios

Patios should be consistent with the grading of the property and located in the rear yard. The materials may consist of natural color concrete, flagstone, slate or brick. The patio size, design, and setback distances to neighboring property lines should be kept in proportion to the home and property. The view of the patio should be softened from the neighbors, possibly accented with shrubs/flowers.

Walkways

Walkways should be consistent with the grading of the property so as to prevent improper drainage. Walkway locations should generally be limited to the side and rear of the house. The materials used for the walkway are limited to natural color concrete, or brick pavers, slate or flagstone.

Landscape Beds

Natural areas (landscape beds) should be made in proportion to the home and property. All front yards, though, should have minimum of 50% grassed area.

Other (gazebos, planters, retaining walls, exterior lighting, etc.)

These require approval by the Architectural Control Committee. Floodlights other than the security lighting provided by builder are not permitted. Spotlights and other exterior lights as for walkways, flowerbeds, and other decorative uses require ACC approval. Care must be taken that lighting not affect neighboring houses or be a distraction to traffic.

Lawn/Grass

Tall Fescue, Bermuda, Zoysia and Centipede grasses are allowed to be used in creating a well manicured lawn and do not require ACC approval. This mix of year-round green and drought tolerant grasses provides a range of options for CHATHAM FOREST residents, and applies to both the front and back yards. Any other types of grass require ACC approval. Residents are encouraged to consult with their neighbor prior to planting the "creeping grasses" (Bermuda, Zoysia or Centipede) and are asked to take reasonable precautions if the neighbor does not want that type of grass on their property. Non-grass replacements to sod, such as stone or gravel, are not permitted, except in Landscape Beds and Gardens. Residents must maintain their lawns. Failure to care for a lawn impacts not only that property, but also adjacent properties visually and physically because of runoff, drainage and spread of weeds.

Antennas & Satellite Dishes

Antennas and Other Attachments. No permanent attachments of any kind or character whatsoever (including, but not limited to, television and radio antennas and satellite dishes or other device for reception of television or radio signals) shall be made to the roof or exterior walls of any Dwelling or other building on any portion of the Properties, nor shall the same be located on any portion of the Properties outside of any Dwelling or other building, unless such attachments first shall have been submitted to and approved by the Architectural Review Committee. Provided, however, the Association shall not prevent access to telecommunication services in violation of any Legal Requirement. Generally, exterior antennas, satellite dishes greater than one meter (39 inches) in diameter, or satellite dishes or other reception devices located in or on the front of a Dwelling or other building, will not be allowed on the Properties. Provided, however, (i) an Owner may install an antenna permitted by any applicable architectural guideline upon prior written notice to the Architectural Review Committee; (ii) the Architectural Review Committee may approve other antennas in appropriate circumstances; and (iii) the Architectural Review Committee may amend existing guidelines and/or establish additional guidelines as technology changes. Further provided, the Association may, but shall not be required to, install and maintain antennas, satellite dishes or similar equipment in or on the Common Property to serve the Common Property and/or the Properties. No outdoor clotheslines shall be allowed on any portion of the Properties.

Storage Sheds

Appearance

Storage sheds must be of the same color scheme as the house. The shed must be in proportion to the house, but in no case shall exceed 120 square feet in total floor space. Storage sheds require ACC approval.

Location

Sheds must be located in the rear yard, and in some rare instances, can be located in the side yard. When possible the shed should become a permanent part of the house. It is up to the homeowner to check for easements or setback restrictions that may affect placement of the shed. **NOTE:** *The Town of Pittsboro and Chatham County may require that a Building Permit be obtained for a shed of **any size**. The shed must **NOT** be closer than 10 feet to any side property line or a property line parallel to a street such as with a corner lot.*

Materials

Sheds should be constructed of durable materials that match the house in appearance. The shed must be permanently affixed to the ground via a concrete slab floor or footing anchors in the corners.

Evergreen shrubs may be required to buffer view from neighboring lots in certain situations.

Basketball Goals, Trampolines & Other Sports Equipment

Basketball Goals - General

Basketball goals fall into three categories: 1) portable, 2) permanent pole-mounted, and 3) permanent mounted to the house. As with all other exterior changes, homeowners are required to submit applications for permanent basketball goals and, if approved, are required to perform periodic maintenance as necessary to keep it in good shape. Slope of the driveway should be considered when planning a basketball goal installation.

Portable Goals

Portable basketball goals do not require Architectural Control Committee approval. Portable goals should be stored out of sight when not in use. Failure to properly store portable goals may result in possible fines.

Further, portable goals should be sufficiently secured when in use to prevent injury or property damage. Portable goals should be positioned to avoid impact to adjoining property, streets, and personal safety.

Permanent Pole-mounted Basketball Goals

A permanent goal to be mounted on a pole on a property is subject to Architectural Control Committee approval for placement and color. Goals should be placed to maximize child safety and to minimize impact to lawns and neighboring property. Worn nets shall be replaced or removed in order to maintain a neat appearance.

Permanent Goal Mounted to a House

A permanent goal to be mounted to a house on any property is subject to Architectural Control Committee Approval for placement and color. A permanent goal mounted to the front of a house must be located above the garage door. The color of the backboard, if not clear, shall blend in with the color of the house.

Goals mounted to a house shall be secured to the house framing to limit potential damage to siding. Some installations may require additional framing to withstand goal use. Worn nets shall be replaced or removed in order to maintain a neat appearance.

Basketball Goals Trampolines & Other Sports Equipment (continued)

Trampolines

Trampolines do not require ACC approval provided they are placed in the rear yard and located at least 12' away from neighboring property lines. Due to safety concerns, it is highly recommended that trampolines be in fenced yards.

All Other Sports Equipment

All other sports and play related equipment that has been not been specifically addressed in the preceding paragraphs must be stored out of sight when not in use.

Pet/Animal-Related Details

Dog Houses

The installation of doghouses is discouraged. If a doghouse is required, a picture and details must be submitted with the ACC Application including plot plan to show intended placement. Placement must be considerate of adjacent properties.

No fenced dog runs or kennels will be permitted.

Pets/Animals

Only domesticated animals as would be a normally accepted breed or animal will be permitted in the community. Livestock, poultry, and exotic animals are not permitted. Homeowners allowing pets outside must maintain upkeep of yard so as to not allow unpleasant smells to affect adjacent yards.

Flags, Statuary & Other Exterior Details

Flags

Recognizing that flags are a symbol of our patriotism and celebration of spirit whether team, school or holiday season, the ACC will allow one flag per property if attached to the house. The pole may not exceed 50 inches in length. The flag may not exceed 62 inches x 40 inches in size. Respect for the American flag includes proper method of care and display. Freestanding flagpoles require ACC approval.

Statuary

Statuary of any size, shape and material must be submitted for ACC approval.

Trash Receptacles

Trash receptacles may not be placed in direct view from the street. Storage inside the garage is preferred. In the event that outside storage is necessary, screening must be installed and vegetation planted to diminish visual impact. ACC approval is required for trash receptacle screen. Care must be maintained to minimize impact on adjacent neighbors.

Holiday Decorations

Holiday décor is permitted with the restriction that it is temporary to the season. For example, Christmas decorations may be put up after Thanksgiving and must be completely removed by January 10th of the month following. Thoughtful consideration should be given to the multi-cultural residents of the neighborhood and decorations and/or lighting should not cause adverse impact to adjacent neighbors.

Mailboxes

Mailbox and Post installed in the Chatham Forest Community are as mandated as the "Standard" Mailbox and Post. The standard is as furnished by "Rodney's Signs", Apex, NC for the Chatham Forest community. **No other style is allowed.**

Responsibility for furnishing and installation is to be consistent with the Property Owner. Builders who are Lot / Property Owners are responsible for furnishing and installation and said Mailbox / Post must be in place prior to conveyance / transfer of new construction / property. Should said Mailbox / Post not be installed prior to the conveyance of the home / property the responsibility for said installation will transfer to the current Property Owner of Record. Should the Property Owner of Record fail to produce the noted Mailbox / Post the CFHOA will have said Mailbox / Post installed at the Property Owners expense or as provided by the Declaration of Covenants, Conditions & Restrictions.

The homeowners must maintain their Mailboxes. Rusty or broken Mailboxes must be replaced, repaired and / or repainted. Should a repair or replacement need arise, the mailbox and post must be replaced / repaired with an, or, to the, identical box, post and color so as to maintain continuity in the community. If a situation arises whereas the current standard is no longer available, application must be made to the ACC for the closest similar model.

Please Note; Mailboxes are to remain as originally installed and as original in color (Forest Green) with a red flag. The affixation of flags, decals, wraps, lettering or signage to mailboxes in CHATHAM FOREST is **prohibited**.

Yard Lights

Yard lights (post type) are mandatory in the Chatham Forest community. Yard Light style is to remain as standard and consistent throughout the community. Yard Lights are to be installed no later than the completion of the original home construction and closing thereof / occupancy. Yard Lights may be gas or electric. Solar powered yard lights may be used but the style must be identical to the standard light.

Responsibility for furnishing and installation is to be consistent with the Property Owner. Builders who are Lot / Property Owners are responsible for furnishing and installation and said Yard Light must be in place prior to conveyance / transfer of new construction / property. Should said Yard Light not be installed prior to the conveyance of the home / property the responsibility for said installation will transfer to the current Property Owner of Record. Should the Property Owner of Record fail to produce the noted Yard Light the CFHOA will have said Yard Light installed at the Property Owners expense or as provided by the Declaration of Covenants, Conditions & Restrictions.

Existing "Gas" Yard Lights may be retrofitted with an electric or solar conversion providing the light style / appearance is not changed or altered.

Standard Yard Lights

Modern Home Products

Gas, #HK-1A

Electric, #HK 1AE

Post, #PO

Pools

All pools, with the exception of wading pools, MUST be approved by application and in writing by the ACC Committee prior to installation. With the exception of "wading pools" all pools must be "in-ground" installations. Pools are required to be enclosed by a minimum five feet (5') high fence, with locking gates, gates should be locked at all times. Fences are to comply with the ACC Guidelines. Pools are required to be set-back no less than ten feet from any property line and must be within the boundary of each side of the house extended in a straight line to the rear property line.

No diving boards or water slides are permitted.

"Wading pools" are inflatable pools with a water depth capacity, which does not exceed twenty-two inches (22"). Wading pools can be deflated and stored away and do not include, require or employ any type of filtration system.

At no time shall any pool, wading or otherwise extend beyond the boundary of each side of the home as extended to the rear property line.

All pools must meet all State, County and Local Codes, Zoning and Compliance.

Please be advised, any Home Owner choosing to have any pool, wading or otherwise, constructed or placed, on said Home Owner's property shall bear total responsibility / liability for said pool and use thereof. At no time and under no circumstances shall the Chatham Forest HOA, the Board of Directors, the Association Management Company or any Committees of the HOA be liable for any actions or circumstances of any kind and shall be held harmless.

Water Ponds/Falls/Fountains

Decorative water pools, fountains, and falls are permitted with written approval of the ACC prior to installation. There shall be no "recreational" use of such decorative displays.

Section IV: Maintenance

Maintenance

It is the responsibility of each homeowner to maintain his/her property in such a way so that it adds to the overall beauty and harmony of the subdivision. Each homeowner should take this responsibility seriously, as failure to do so can negatively affect the value of his/her property as well as the surrounding properties and subdivision as a whole.

There are many areas in and around the home, which should be inspected, regularly to insure the property is in good repair. These include but are not limited to:

- Trees, Shrubbery and Lawns
- Decks
- Fences
- Driveways and Sidewalks
- Playground Equipment
- Exterior Siding
- Roofing
- Garbage Can Storage

Deterioration

If at any time the Board of Directors is made aware of a property that has deteriorated to the point that it is affecting the aesthetics of the community, the Architectural Control Committee will be requested to make a site inspection. The Committee will then make a recommendation for action to the Board of Directors.

Based on the severity of the deterioration, the homeowner will be given a specified period of time in which to make the necessary repairs. If, after that time, the repairs have not been affected to the satisfaction of the Board, the Board has the obligation of enforcement as described in the Declaration of Covenants, Conditions and Restrictions for CHATHAM FOREST Homeowners Association.